

Application

The units compli 1500 and 2500 have been designed for the disposal of sewage from industrial, public and semi-public buildings, apartment blocks, flats, etc. for an uncontrolled effluent flow and specially where a safety factor must be provided.

The entire unit is damp- and floodproof and thus ideally suited to placing in unventilated areas or basements subject to accidental flooding. The control panel must be installed in a dry, ventilated position safe from flooding.

Maintenance is extremely simple; the tank has 2 top mounted inspection/cleaning apertures and, if necessary, the pumps can be removed/replaced in minutes and without disturbing the tank assembly.

Description

Pumps Vertical, single-stage, submersible, single channel impeller with volute casing and horizontal discharge branch, flanged on duckfoot bends, which are on noise- and vibration absorber.

Bearings Common shaft for pump and motor, greased ball bearings.

Motor Submersible, type of enclosure IP 68, insulation class F, winding thermostat protects the motor from overload, automatic starting via rotary level control and control unit, method operation S3 according to VDE.

Shaft seal Silicon carbide mechanical seals (independent of rotation), oil-chamber and artificial carbon mechanical seal (or double shaft seal) towards the motor section, safe to run dry, a seal leak detector can be connected, power supply through rubber insulated flexible cable.

Materials Tank made of corrosion resistant and non-polluting polyethylene, pump- and motor-housing, impeller and duckfoot bend from wear resistant GG grey cast iron, shaft against liquid completely covered.

The unit comprises Sewage disposal unit acc. to EN 12050 as construction set, ready for final assembly at site: PE-tank with inlet clamping flange DN 150 and automatic level control with Reed contacts, duckfoot bends, fitting materials, elastic connections for vent-pipe DN 70 and for duckfoot bend with hose band clamps, control panel for alternating duty cycles or, if necessary, on a duty/back-up system with transformer, contactor with overload relays, mains operated alarm device, and volt-free contact for remote failure indicators. The control unit can also be equipped with a microprocessor unit on request. Length of cable from pump to control unit = 10 m. Accessories to be ordered according to the mounting drawing.



▶ Flood-proof

▶ Big storage capacity

▶ Eligible inlet position

▶ PE-tank



Technical data compli 1500/2500

Type	Tank capacity litre	Floor to centre inlet	Cable quality HO7RN-F-	Cable lenght	Weight kg	Code-No.
Duplex units with 1 PE tank						
1525/4 C1	500	700 mm	6G1,5	10 m	253,5	09181
1535/4 C1	500	700 mm	6G1,5	10 m	261,5	09182
1555/4 C5	500	700 mm	10G2,5	10 m	363,5	09183
1575/4 C5	500	700 mm	10G2,5	10 m	373,5	09184
1575/4 B6	500	700 mm	10G2,5	10 m	357,5	09185
Duplex units with 2 PE tanks						
2525/4 C1	1000	700 mm	6G1,5	10 m	300,5	09186
2535/4 C1	1000	700 mm	6G1,5	10 m <td 308,5	09187	
2555/4 C5	1000	700 mm	10G2,5	10 m	410,5	09188
2575/4 C5	1000	700 mm	10G2,5	10 m	420,5	09189
2575/4 B6	1000	700 mm	10G2,5	10 m	404,5	09190

We reserve the right to change specifications without notice.

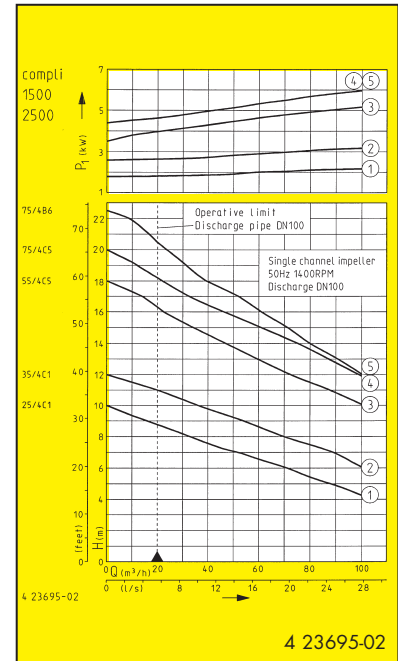

Performance (values per pump)

Type	H [m]	4	5	6	7	8	9	10	11	12	13	14	16	18	20
compli 25/4 C1	104	87	71	51	32	16									
compli 35/4 C1			103	89	72	54	36	21							
compli 55/4 C5							100	87	74	59	45	22			
compli 75/4 C5								100	87	74	44	22			
compli 75/4 B6									91	82	62	41	24		

The minimum flow velocity in the pressure piping must be 0,7 m/s according to EN 12056. This data is represented in the performance curve as a limit of application.

Pump performance is subject to ISO 9906 tolerances

Electrical data

Type	Voltage Volt	Motor rating kW P1 P2	Max. current Amp.	RPM min-1	Max. size solids mm	Inlet flange	Discharge branch n. b. mm	for pipe connection n. b. mm	Vent pipe n. b. mm
compli 25/4 C 1*	3/N/PE~400	2,4	1,90	4,1	1345	100	DN 150	DN 100	DN 70
compli 35/4 C 1*	3/N/PE~400	3,5	2,65	6,8	1410	100	DN 150	DN 100	DN 70
compli 55/4 C 5*	3/N/PE~400	5,8	4,65	10,2	1420	100	DN 150	DN 100	DN 70
compli 75/4 C 5*	3/N/PE~400	7,2	5,90	12,5	1425	100	DN 150	DN 100	DN 70
compli 75/4 B 6*	3/N/PE~400	7,2	5,90	12,5	1425	70	DN 150	DN 100	DN 70

* current 3-phase

Mounting arrangement

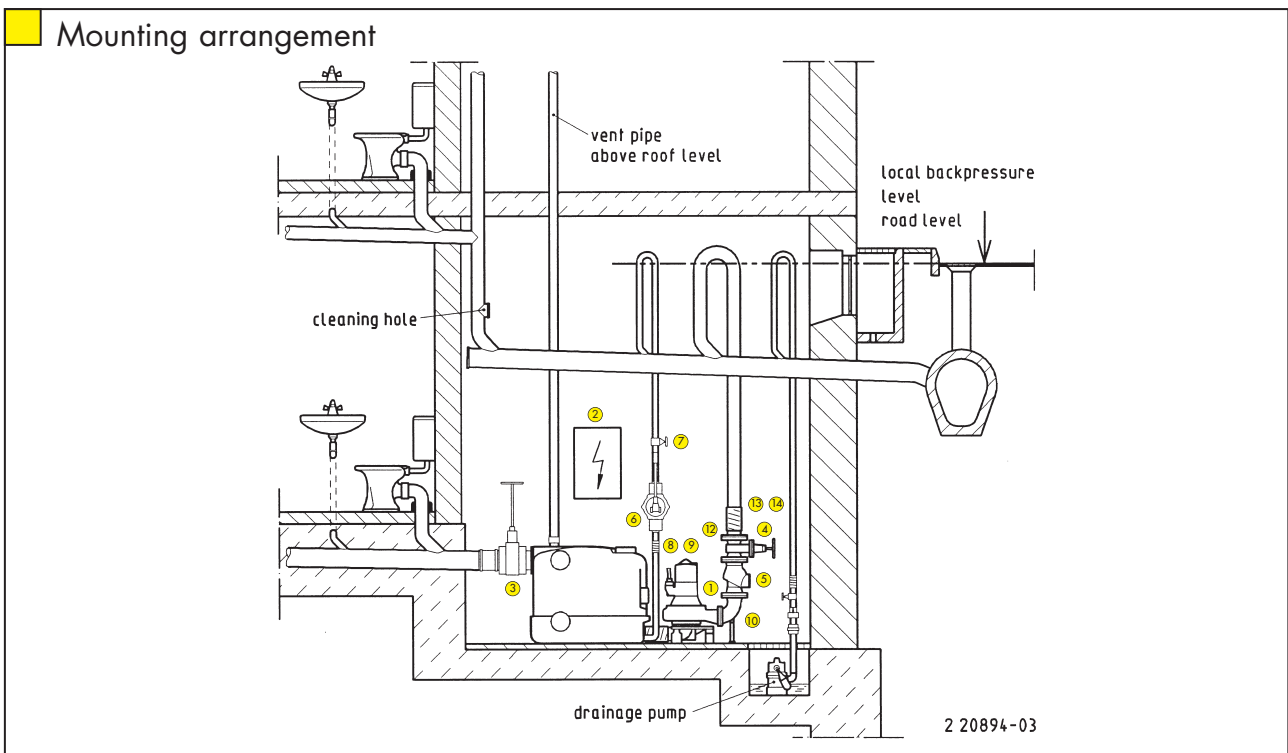

Dimensions (mm) compli 1500

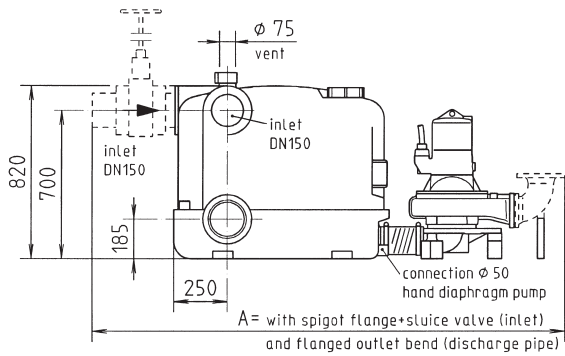

casing	A	B
B6	2255	900
C1	2195	820
C5	2235	870

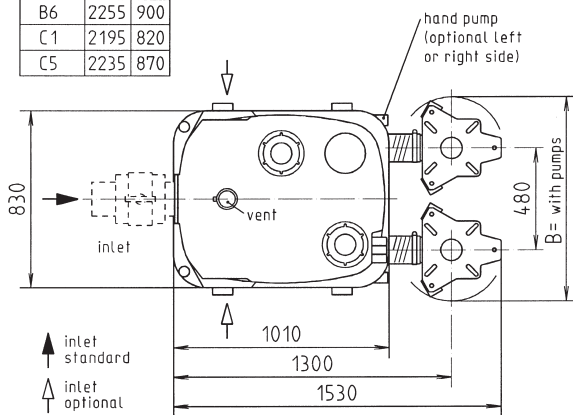

4 23589-04

Dimensions (mm) compli 2500

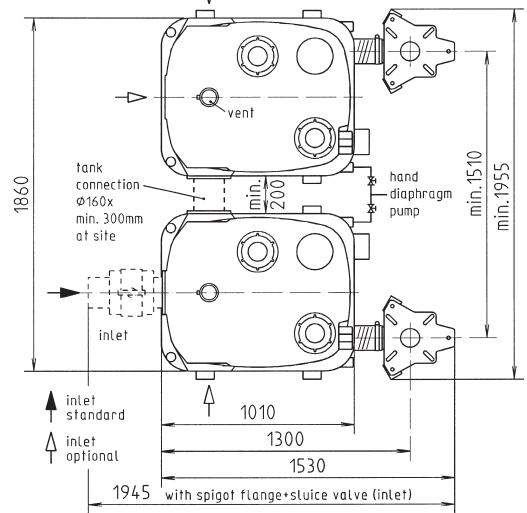
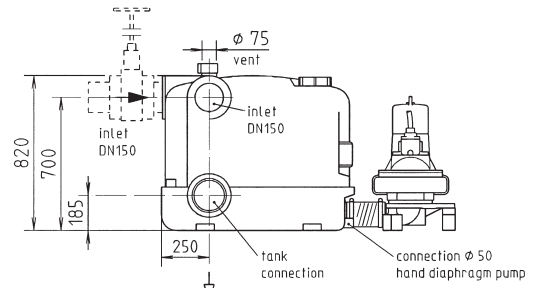

4 20710-05

Dimensions (mm) compli 1500

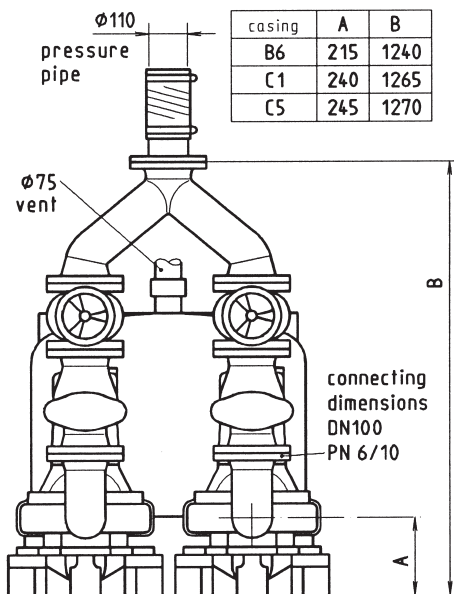

casing	A	B
B6	215	1240
C1	240	1265
C5	245	1270

4 20778-02

Dimensions (mm) compli 2500

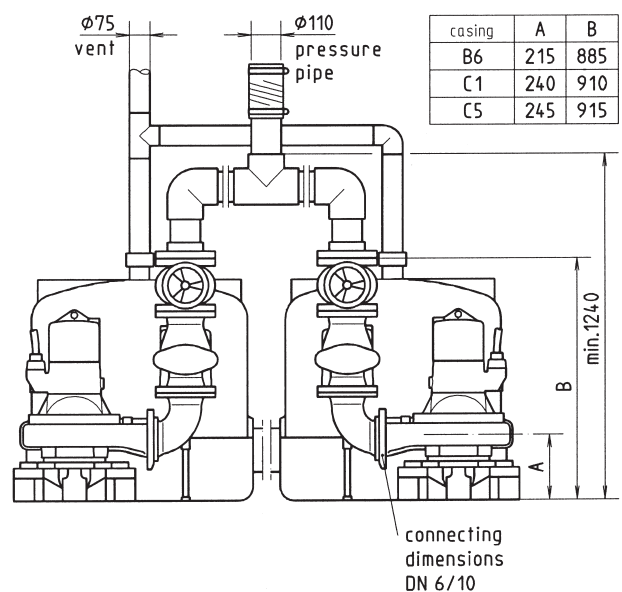

casing	A	B
B6	215	885
C1	240	910
C5	245	915

4 20779-02

Accessories

Code No.

- ① **Seal leak control DKG** (for duplex units 2 DKG) **00252**
- ② **Rechargeable battery** for off the line operation of the alarm system **07562**
- ③ **PVC sluice valve** (two pipe sockets) for inlet 6" **28591**
and tank connection (DN 150) PN 2,5



H	L	E	D	
660	450	110	160	for inlet 6"

- ④ **Sluice valve *** for discharge pipe 4" (DN 100), PN 10, EN 1171 **00329**



H	L	D	
345	190	DN 100	for discharge pipe 4"

- ⑤ **Swing-type check valve *** PN 4, flange PN 10, DIN 3202, EN 12050-4

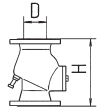

H	D		
	DN	without counterweight	R 101 00325
300	100		

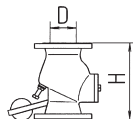

H	D		
	DN	with counterweight, adjustable	R 100 G 00324
300	100		

- ⑥ **Hand diaphragm pump *** for emergency purpose **00255**
(for max. del. height up to 15 m)

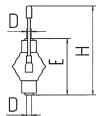

H	F	D
approx. 640	430	1 1/2"

- ⑦ **Stop valve** 1 1/2" (DN 40), PN 16 **11837**

- ⑧ **Elastic connection** 1 1/2" (DN 40), PN 4 **20368**

- ⑨ **Hose band clamp** 1 1/2" **03571**

- ⑩ **Flanged outlet bend *** C 100 **00579**



H	B	C/DN	D/DN
175	120	100 PN 10	100 PN 6

- ⑪ **Y-Piece *** DN 100/100/100, PN 10 (compli 1500 only) **00203**



H	B	C/DN	D/DN
355	480	100	100

- ⑫ **Spigot flange F-KS*** for discharge pipe, DN 100, plastic **08673**

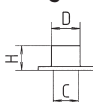

H	D	C/DN flange
153	110	100 PN 10

- Spigot flange *** (F-piece) for discharge pipe, C 100, steel **00688**

100	114	100 PN 10
-----	-----	-----------

- ⑬ **Elastic connection** 4" (DN100), PN 4



H	D	
200	110	for discharge pipe, DN 100, plastic 21043
200	114	for discharge pipe, DN 100, steel 16348

- ⑭ **Hose band clamp *** 4" **03575**

* c/w screws and gaskets

Mounting arrangement

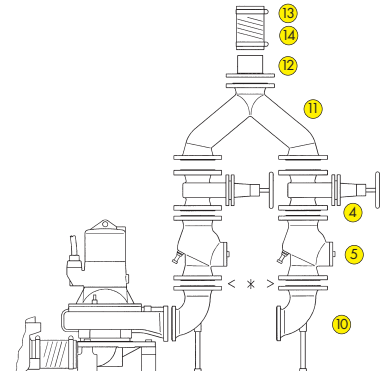

* Reducing adapter can be supplied.

4 22529-02

The various assembly items i. e. tanks, duckfoot bends, pumps and control panel have to be finally fitted as instructions.

Mounting arrangement

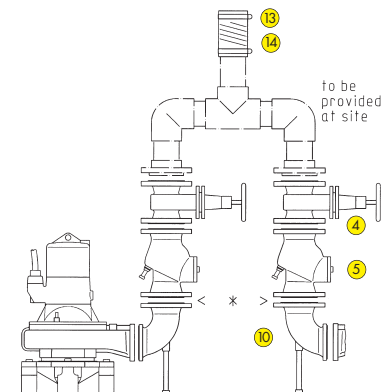

* Reducing adapter can be supplied.

4 22530-02