

## Application

The drainage disposal unit Hebefix V is an easily installed appliance for the disposal of faeces-free waste water above or below backpressure level. It is designed for mounting in a system duct or void but can also be used at other locations due to the little required space, for example in kitchen counters. All grey water objects can be connected, i. e. wash hand basin, shower, tub, sink, washing machine etc. The pumping medium is transported by the unit through a small dimensioned pressure line to the closest downpipe.

The Hebefix V can be used wherever the installation of an additional bathroom or kitchen is required as part of renovation or conversion work. In the bathroom this product is an excellent supplement to the WCfix 260 V which may not be connected to tubs or washing machines in accordance with EN 12050-3.

For acoustic fault signalling the Hebefix V contains an alarm system with reed contact switch.

The appliance is delivered with built-in submersible pump U 3 KS NIRO. It is ready-to-connect to a shock-proof plug and works fully automatically as soon as waste water starts to flow. When installed in bath and shower rooms, the applicable electrical regulations must be observed.

For the installation and for maintenance work a sufficiently large emergency gate has to be planned (accessory).



Hebefix V (pump in the scope of supply)

The minimum flow velocity in the pressure piping must be 0,7 m/s according to EN 12056. This data is represented in the performance curve as a limit of application.

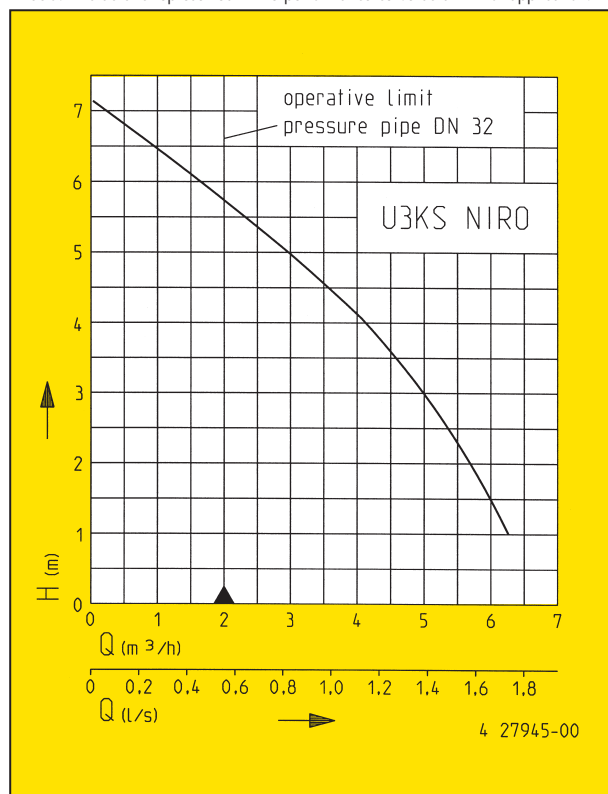

- ▶ Quietly running
- ▶ Ready to connect
- ▶ Easy to maintain
- ▶ Pressure sealed
- ▶ Activated carbon filter
- ▶ Alarm system
  
- ▶ Vortex impeller



We reserve the right to change specifications without notice.  
Pump performance is subject to ISO 9906 tolerances.

## ■ Hebefix V

Type	Height x Length x Width	Cable	Weight	Code No.
Hebefix V	320 x 420 x 180 mm	1,5 m	6,2 kg	<b>9360</b>
<b>Accessoires:</b> Service frame, white, nominal diameter 400 x 500 mm with magnets, to be tiled (dimensions 409 x 509 mm) Stop valve				<b>27090</b> <b>11836</b>

## ■ Performance

Type	Delivery head H [m]	1	2	3	4	5	6
Hebefix V	Flow rate Q [m <sup>3</sup> /h]	6,5	5,5	5	4	3	1,5

## ■ Electrical data

Type	Type of current	Voltage Volt	Motor rating kW P <sub>1</sub> P <sub>2</sub>	RPM min <sup>-1</sup>	F.L.C. Amp.	Motorprotection	Plug
Hebefix V	1-phase	1N~230	0,32 0,20	2720	1,4	(incorporated) IP 68	safety-

## ■ Mounting arrangement

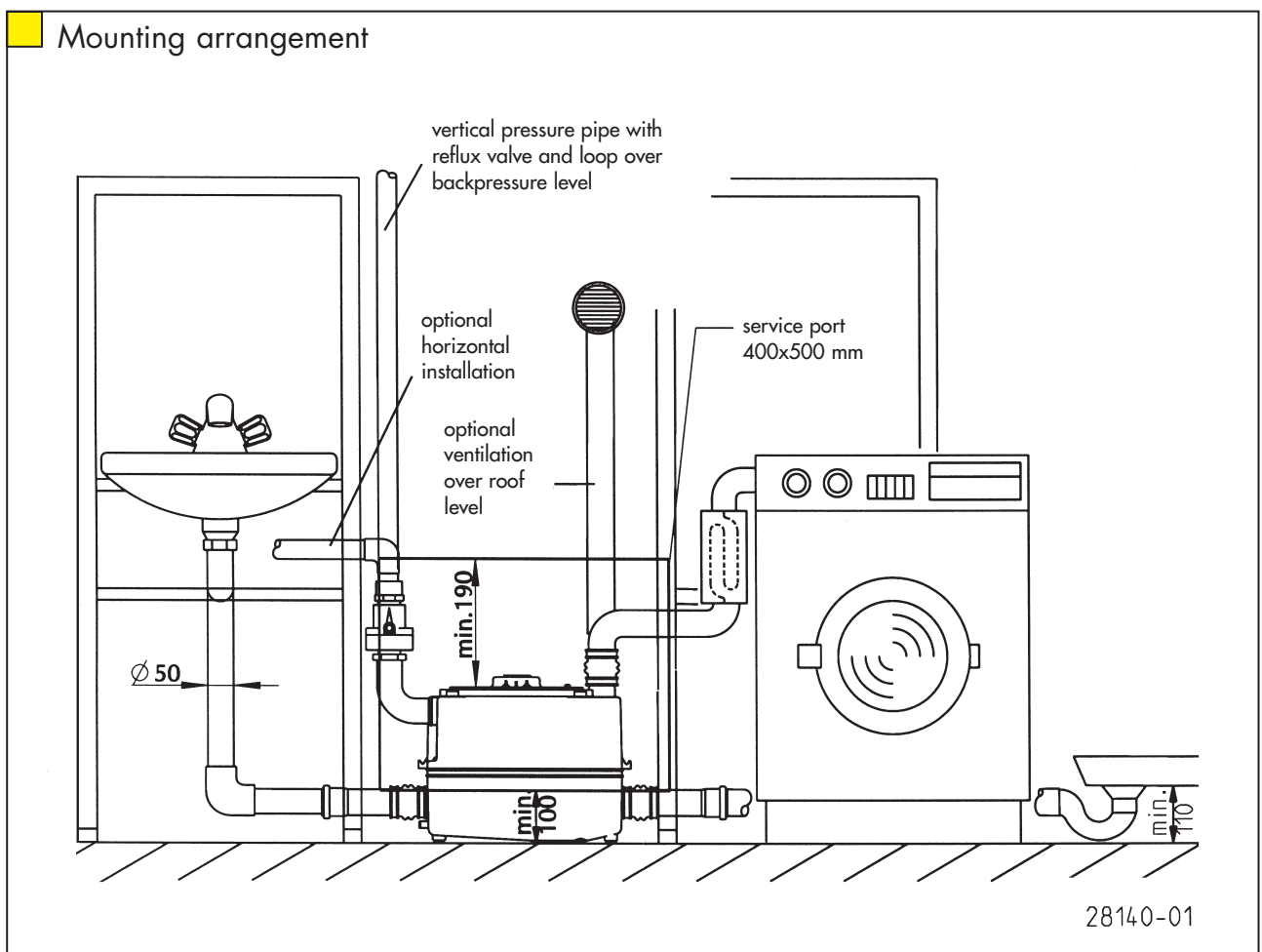

## Installation

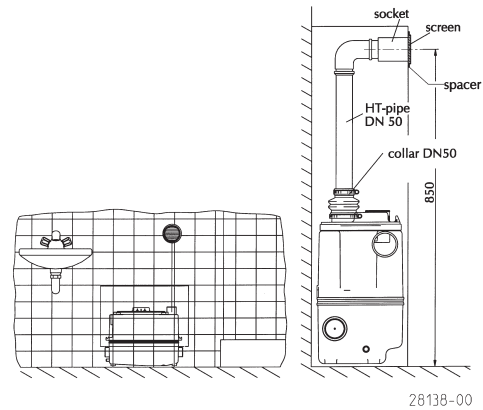
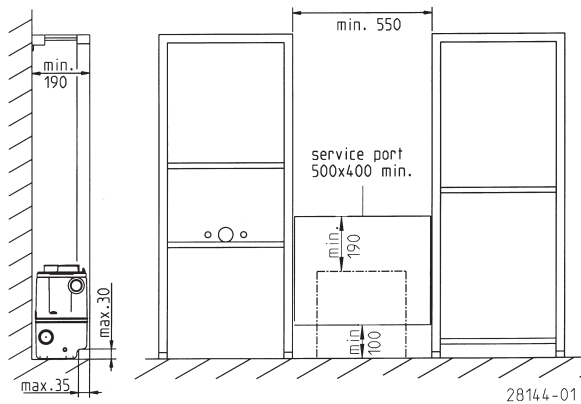

The Hebefix V can be combined with all commercial wall facing installation systems. The distances shown between the elements must be adhered to. Plinths attached to the floor, for the alignment of several items, can be placed underneath the tank to save space.

For correct operation, venting of the system is essential. The installation method shown prevents the occurrence of moisture behind the facing wall. All necessary special components form part of the scope of supply.

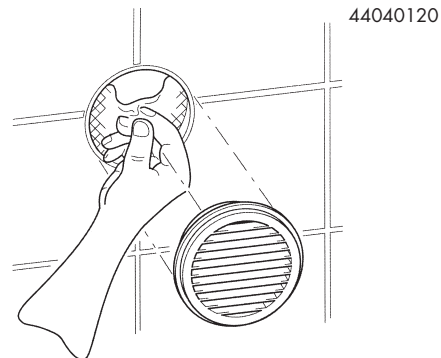
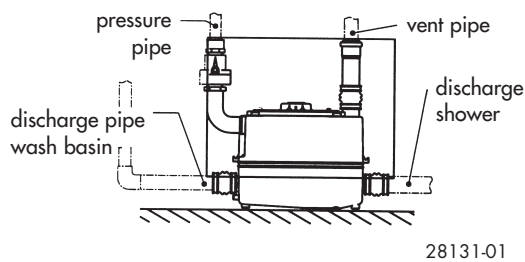

The assembly is placed into the installation space through the assembly opening and flexibly connected to the supply pipes by means of the sleeves and pipe brackets.

To change the activated carbon filter in the unit venting system, only the push-fit venting screen has to be removed.

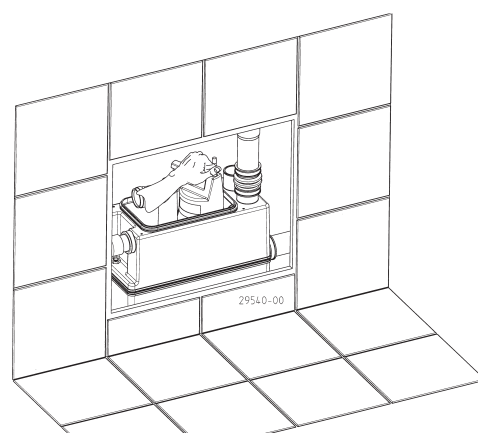
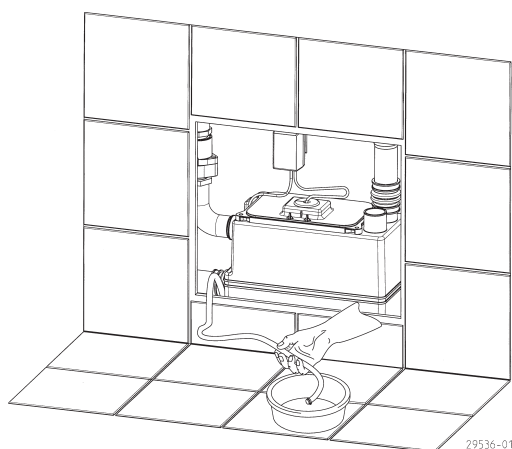

In emergency situations the system can be drained via a pre-fitted drain hose.

The motor/pump unit can be easily removed as a compact assembly.

## Technical data

### Construction

Tank with built-in submersible motor pump U 3 KS NIRO with fully enclosed shaft, with 10 mm free passage and hydraulic system in EIP technology with open 5-blade impeller, pressure outlet elbow of the tank made of elastomer with connecting bushing for pressure pipe (made of PVC, PP or PE) DN 32 with NW 40 and an inner diameter (= LW) of 36 mm. Inlet connections in DN 50 (HT pipe). Connection via an elastic connector cuff to the muffs of the unit.

### Pump

Vertical, single-stage, submersible, protection class IP 68, insulating material class B, motor thermostat for safety shut-down in case of overheating with automatic re-start upon sufficient cooling, integrated level control, moisture sealed cable inlet for pump protection in case of cable damages, continuous operation possible due to ducted cooling of the motor.

### Control

Automatic floating switch, alarm unit with separate reed contact floating switch

### Materials

Motor housing and shaft made of stainless steel, tank, pump housing and impeller made of plastic, connecting cuffs and outlet elbow made of elastomer

### Seal

Shaft seal by rotary shaft seals and intersected oil chamber, safe to run dry

### Extend of delivery

Appliance including pump according to EN 12050. Ready-to-connect with cable and plug, complete with connecting cuffs, outlet elbow, swing-type check valve 1¼", transfer nipple, inlet for ventilation line, activated carbon filter, clips and fastening material for buoyancy protection, outlet hose with closing plug.

## Dimensions (mm) Hebefix V

