



sc instal pompe sb s.r.l  
sura mica sibiu  
principala 96  
0040-557270  
Tel. 0755418009 Fax 0269577151

## Duty Curve



<Kunde:>  
<Straße>  
<PLZ / Ort>  
<Telefonnummer>

Project <Projekt:>  
Project ID Kennlinie / Performance Curve  
Created by: <Erstellt durch>

Page: 2 / 3  
Date: 2009-02-26

### US 75 D

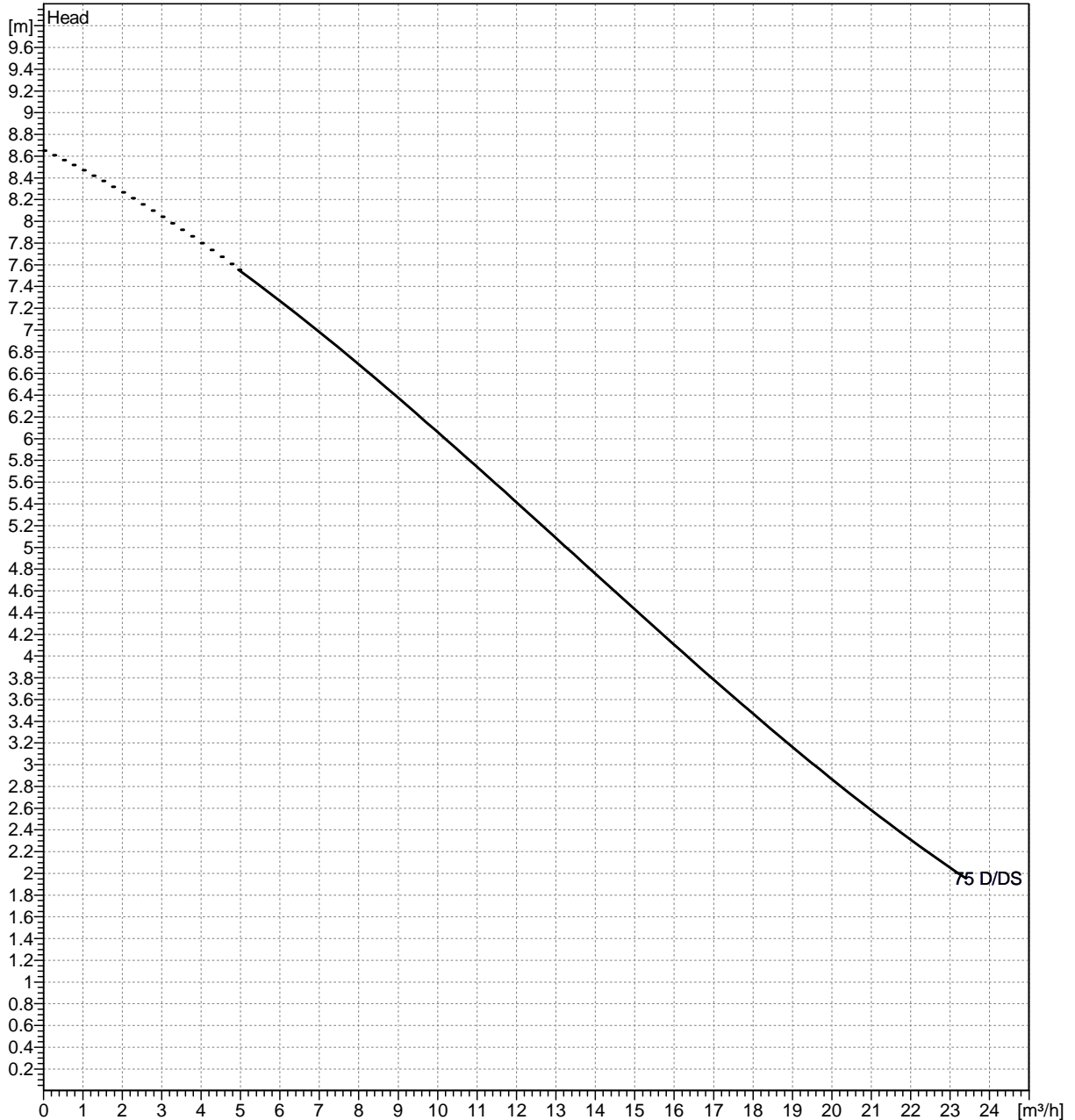

**Pump:** US 75 D

**Fluid:** Wastewater

**Operating point (single):**  
**Operating point (parallel):**

sc instal pompe sb s.r.l  
 sura mica sibiu  
 principala 96  
 0040-557270  
 Tel. 0755418009 Fax 0269577151

### Main dimensions



<Kunde:>  
 <Straße>  
 <PLZ / Ort>  
 <Telefonnummer>

Project <Projekt:>  
 Project ID  
 Created by: <Erstellt durch>

Page: 3 / 3  
 Date: 2009-02-26

### US 75 D

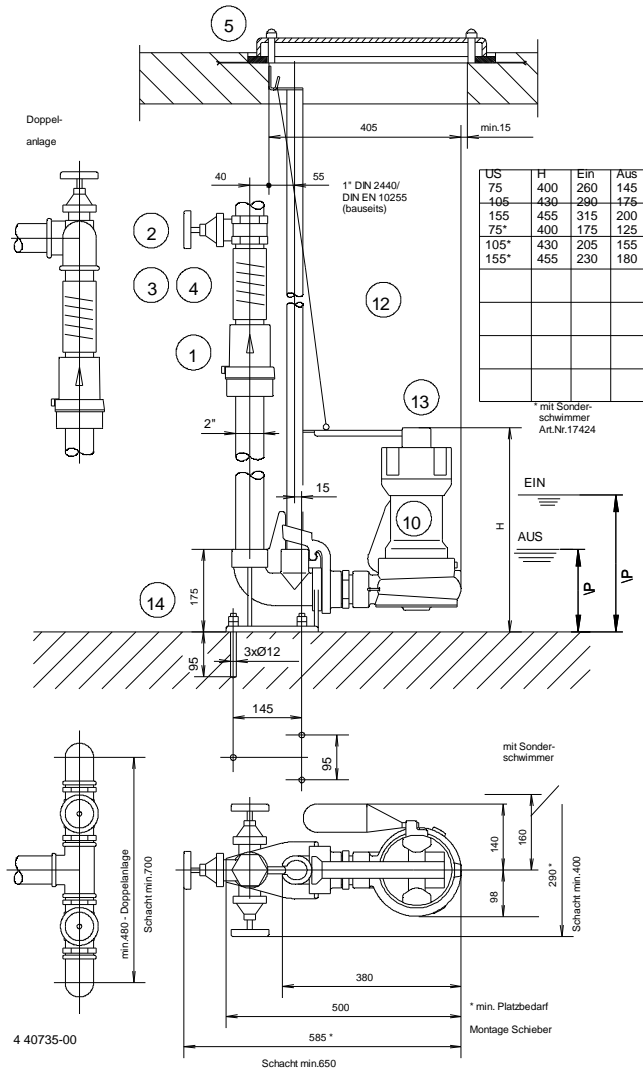

Abmessungen in mm

Suction port:  
 Discharge port: G 2"  
 Weight in kg: 13.1